

Frigomilk® New 500 Line



Frigomilk® G4



Frigomilk® New 500 Line



Open Milk cooling Tanks from 500 to 2000 litres

TECHNICAL SPECIFICATIONS

MANUFACTURE:

- AISI 304 stainless steel inner tank and outer casing.
- Total primary Trapcold™ laser welded evaporator surface with maximum yield.
- Very thick ecofriendly and performing insulation by polyurethane foam.
- DN50 outlet-butterfly valve included.
- AISI 304 stainless steel arm.

- Millimeter stainless steel dip-stick with conversion-table in litres for the measurement of milk-level.

COOLING SYSTEM:

- Non-icing cooling even with low filling level.
- Direct expansion.
- R404A refrigerating fluid for all models.
- Stainless steel cover.
- High and low pressure switches.
- Compact and easy to install.
- It complies with EN 13732.

ELECTRIC SYSTEM:

- FIPO 3 electronic milkcontroller.
- Milk temperature check and display.
- Stirring program.
- Thermal protection for threephase compressors as well as compressors' inner protection.
- Electrical feeding cables with standardised plug (male).
- 230V 50HZ single-phase feeding or 400V three-phase feeding 50HZ + neutral.

BY REQUEST:

- Stainless steel elbow.

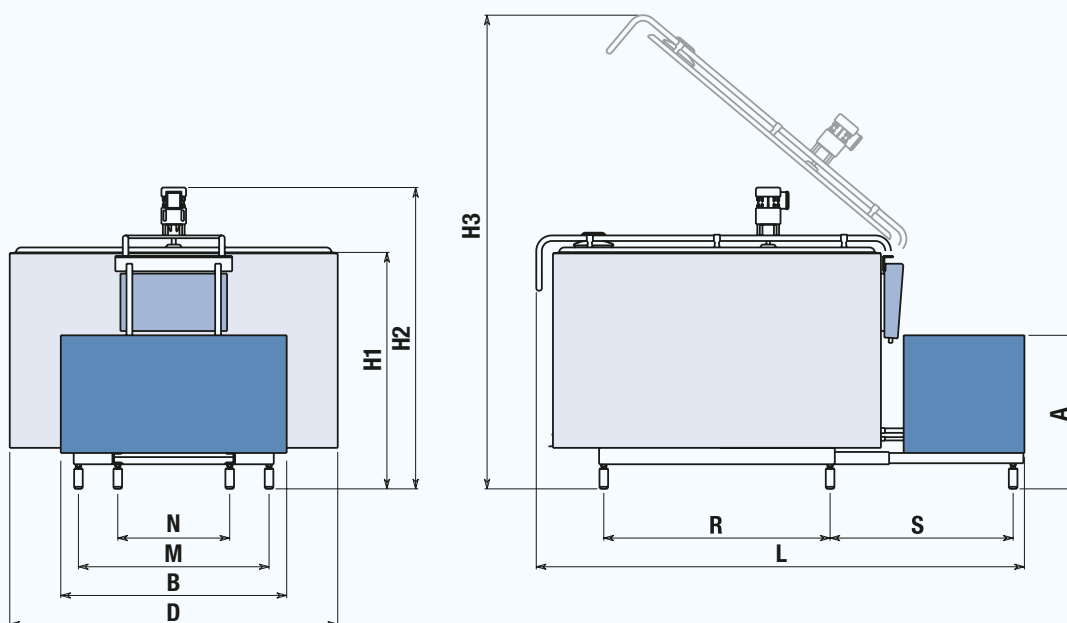

MODEL	VOLTAGE (volt)	VOLUME (litres)		DIMENSIONS					ADJUSTABLE FEET POSITIONING				CONDENSING UNIT			WEIGHT (kg)	
		Max	Nominal	L (mm)	D (mm)	H1 (mm)	H2 (mm)	H3 (mm)	M (mm)	N (mm)	R (mm)	S (mm)	A (mm)	B (mm)	Compr. HP		
500	2MM	1.230	525	1960	1218	845	1080	2100	700	540	835	850	570	910	1,2	192	
	2MT	3.400															
1000	2MM	1.230	1090	2040	1390	1145	1470	2600	820	540	955	720	750	1200	3	275	
	4MT	3.400										2270	850	570	910	1,2	251
												2040	720	750	1200	3	275
1500	4MT	3.400	1580	2250	1600	1225	1550	3010	930	540	1105	750	750	1200	2,3	330	
	2MT												850	1340	4	350	
2000	4MT	3.400	2045	2250	1600	1455	1780	3240	930	540	1105	750	750	1200	3	380	
	2MT												850	1340	5	447	

2MM = 2 milkings single phase
 2MT = 2 milkings three phase
 4MT = 4 milkings three phase

Any specification may be modified without notice. Rev. n. 1

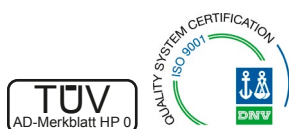

FIG s.p.a
 Via Trivulzia, 54
 23020 Mese (Sondrio) Italy
 Stab. Amm. (Factory - Head Office):
 Tel. +39 0343 41051 - fax +39 0343 41304
 fic@fic.com - www.fic.com

